

## VALVULAS: VALVULA RETENCION DOBLE DISCO

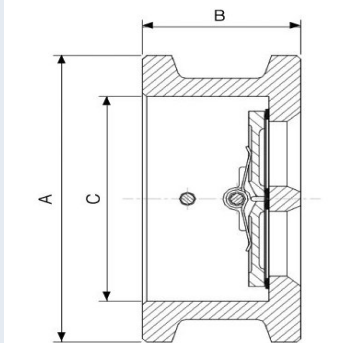

### MATERIALES:

CUERPO	FUNDICION GRIS GG-25
DISCOS	ACERO INOXIDABLE AISI-304
EJE	ACERO INOXIDABLE AISI-420
MUELLES	ACERO INOXIDABLE AISI-316
EJE TOPE	ACERO INOXIDABLE AISI-420
JUNTAS	JUNTAS DE SEPARACION EN TEFLON



MED	50	65	80	100	125	150	200	250	300	350	400	450	500	600
A	106	126	141	161	191	217	272	327	382	442	494	554	616	733
B	54	54	57	64	70	76	95	108	143	184	191	203	213	222
C	66	78	90	115	141	170	210	273	324	356	406	457	508	600

## DIAGRAMA DE PERDIDAS DE CARGA QUE GENERA

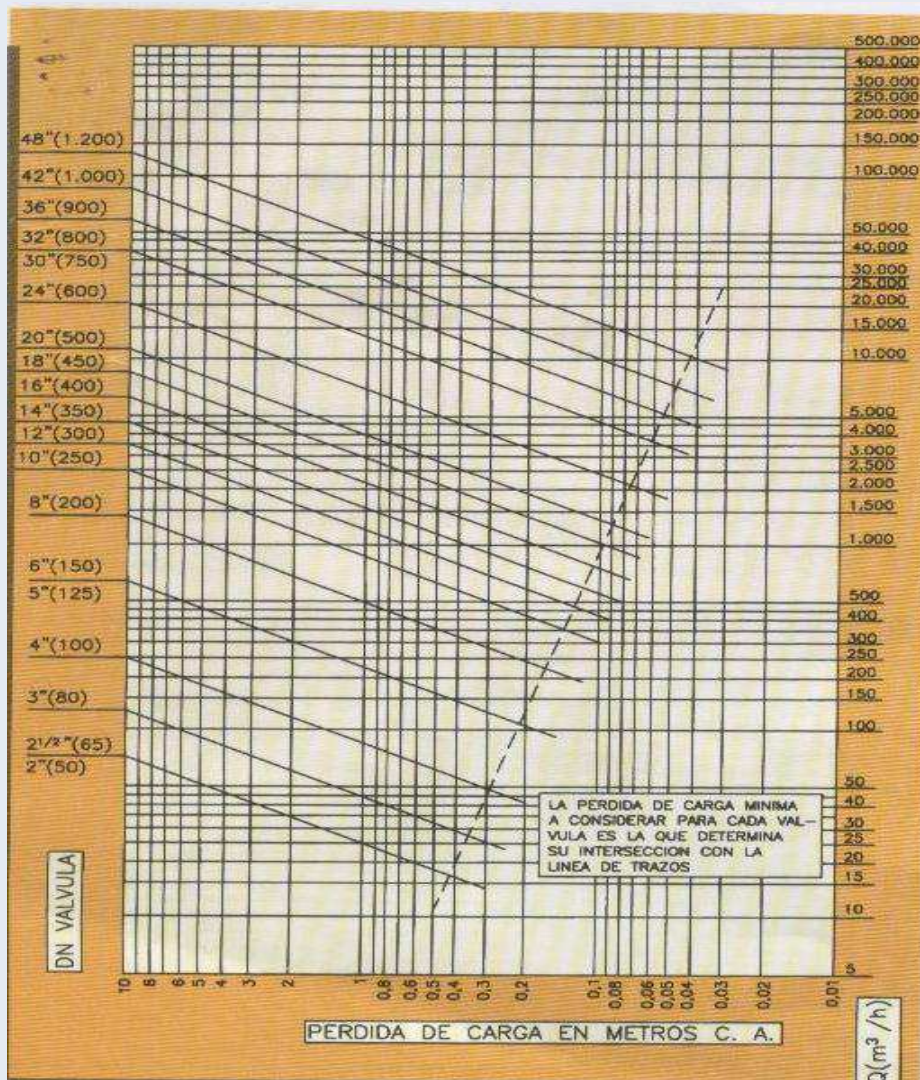

TEMPERATURA DE -10° C A 120 ° C

PARA IMPULSIONES DE AGUAS LIMPIAS O POCO CARGADAS